

ELECTROMECHANICAL LOCK

Promix-SM490**Promix-SM491****Promix-SM492****OPERATING MANUAL**

Technical description. Installation manual. Certificate.

ПШБА.304268.401 PЭ

PATENT FOR INVENTION

No.114333

1. PURPOSE

Electromechanical locks series Promix-SM490, Promix-SM491, Promix-SM492 with a pin locking mechanism (below called the locks) are designed for restriction of access to:

- luggage locker cells, built-in lockers, drawers for storage of documentation, etc.;
- refrigerator cabinets, chests, cigarette cabinets and other retail space equipment;
- cabinets for storage of drugs and chemicals;
- automatic cash dispensers, electronic terminals, retail and vending apparatus;
- electric cabinets, control cabinets, process equipment;
- lifts, airlocks, etc.

2. LABELING

The label stuck to the lock body contains the following information:

1. Lock model.
2. Patent number.
3. Nominal supply voltage.
4. Nominal consumed current.
5. Date of manufacture and QCD mark
6. Identification number.
7. Manufacturer's website.

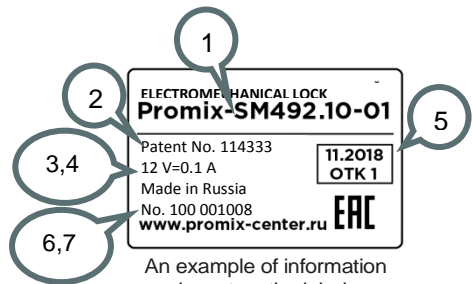
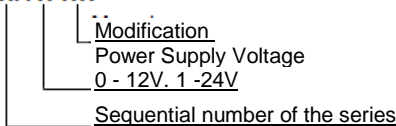
**Promix-SM49X.1 X-XX**

For the list of lock modifications that can be ordered, see 5.2.

The color of the product is shown on the sticker stuck to the box, after the product name. Series colors: **Silver**. Other colors are provided optionally.

3. SET OF DELIVERY

3.1 DELIVERY PACKAGE of Promix-SM490

- | | |
|----------------------|-------|
| 1 – Lock | 1 pc. |
| 2 – Operating manual | 1 pc. |

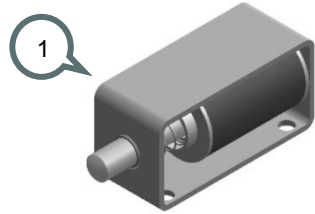

3.2 DELIVERY PACKAGE of Promix-SM491

- | | |
|--|--------|
| 1 – Lock | 1 pc. |
| 2 – Latch | 1 pc. |
| 3 – Self-tapping screw 3.5x15 (cup head) | 4 pcs. |
| 4 – Operating manual | 1 pc. |

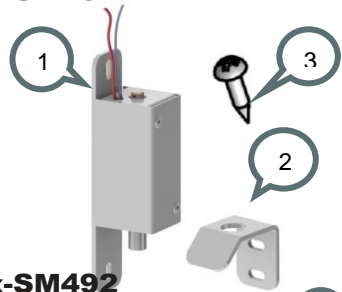

3.2 DELIVERY PACKAGE of Promix-SM492

- | | |
|--|--------|
| 1 – Lock | 1 pc. |
| 2 – Latch | 1 pc. |
| 3 – Self-tapping screw 3.5x15 (cup head) | 6 pcs. |
| 4 – Operating manual | 1 pc. |

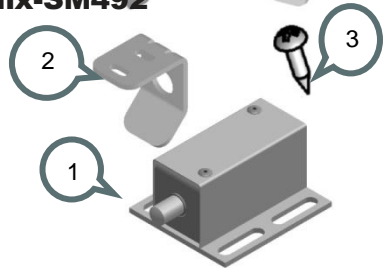

Check completeness of the lock set when buying! After buying, the manufacturer will not accept claims related to incomplete set.

4. DESIGN AND PRINCIPLE OF OPERATION

As voltage is applied, the armature is drawn inside the lock moving in the opposite direction.

In the locks Promix-SM491 and Promix-SM492, as the door is closing, the latch presses the lock armature inside, and the lock armature is blocked in the opening of the latch. As voltage is applied, the armature moves in the opposite direction and comes out of the latch opening making it free.

The locks Promix-SM491 and Promix-SM492 are provided with the possibility of emergency opening in case of interruption in power supply; a fishing line included in the delivered set is used for this purpose. For emergency opening, one should pull the line, and the armature will be drawn into the lock body.

Overall and mounting dimensions of Promix-SM490 series lock.

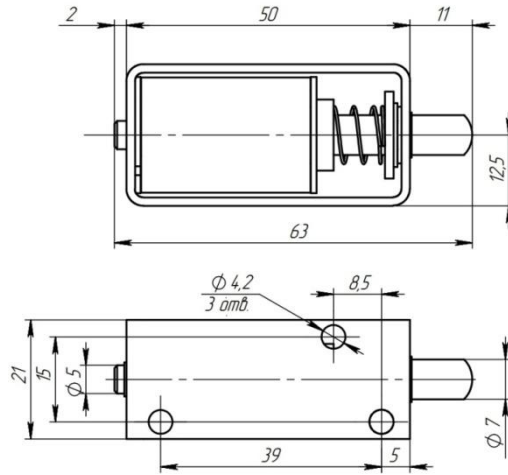

Overall and mounting dimensions of Promix-SM491 series lock.

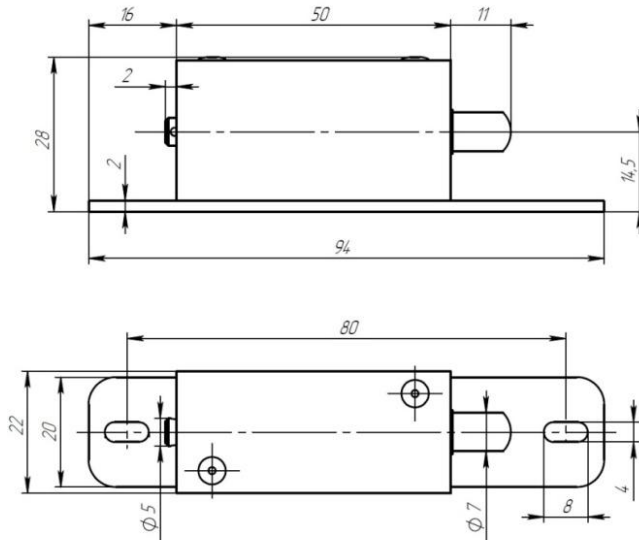

Overall and mounting dimensions of Promix-SM492 series lock.

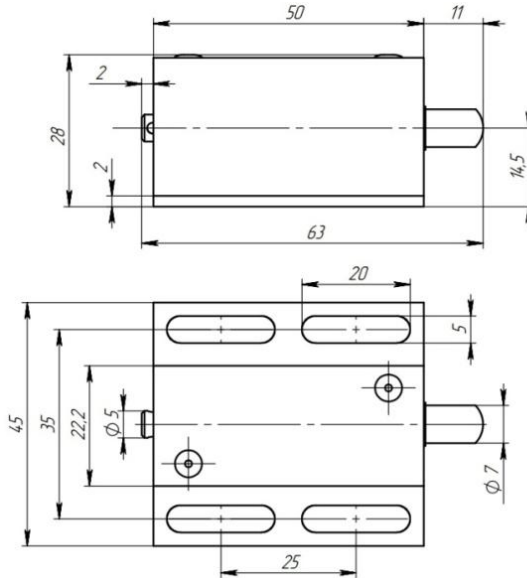

Overall and mounting dimensions of the latch.

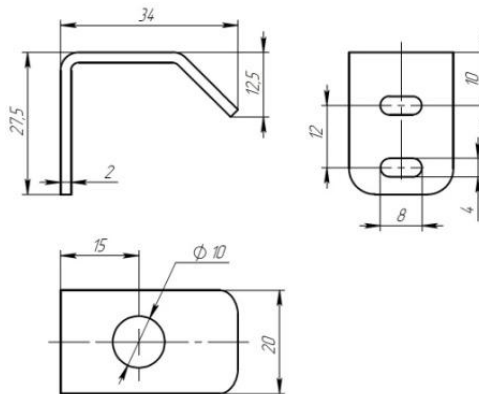

5. TECHNICAL DATA

5.1 OPERATING CONDITIONS

The lock operation environment must be explosion-safe, free of current-conducting dust or gases that cause metal corrosion and destroying insulation of current conductors and electric elements, free of current-carrying dust or water vapor, and preventing ingress of water, steam, fuel and lubricants.

Climatic conditions of operation – Y3.1 as per GOST 15150-69 with extended temperature range:

- ambient temperature: from -40 to +50 °C;
- Relative air humidity: not higher than 98% at 25°C or lower temperatures without moisture condensation and hoar-frost formation;
- installation indoors or outdoors excluding ingress of moisture, dust, dirt, etc. inside the lock.

5.2 TECHNICAL DATA

Series	Promix-SM490	Promix-SM491	Promix-SM492
Holding force (not less than), kg	300	150	250
Lock weight (not more than), kg	0.1	0.17	
Power wire length, m	0.15		
Mean operating life, number of actuations, not less than	100 000		
Actuations to a first failure, not less than	40 000		

Modification	Operating position	DC supply voltage U, V	Current consumed, A
Promix-SM490.10 Promix-SM491.10 Promix-SM492.10	↔ (horizontally) ↓ (vertically)	10÷14	0.65 0.1 (at 12V)
Promix-SM490.10-01* Promix-SM491.10-01* Promix-SM492.10-01*	↔ (horizontally) ↓ (vertically, with armature upwards)	11÷14	0.28 0.1 (at 12V)
Promix-SM490.10-02* Promix-SM491.10-02* Promix-SM492.10-02*	↔ (horizontally) ↓ (vertically, with armature downwards)	11÷14	0.28 0.1 (at 12V)
Promix-SM490.11-01* Promix-SM491.11-01* Promix-SM492.11-01*	↔ (horizontally) ↓ (vertically, with armature upwards)	22÷26	0.24 (at 24V)
Promix-SM490.11-02* Promix-SM491.11-02* Promix-SM492.11-02*	↔ (horizontally) ↓ (vertically, with armature downwards)	22÷26	0.24 (at 24V)

Modification	Ambient temperature $T_{amb.}$, °C	Duration of supply voltage pulse T_{ON} , s	Minimum pause between voltage pulses, s
Promix-SM490.10	-40 to +35	0.5+60	6x T_{ON}
Promix-SM491.10	-35 to +50		10x T_{ON}
Promix-SM492.10			
Promix-SM490.10-01*	-40 to +35	not regulated	
Promix-SM491.10-01*	-35 to +50	0.5+120	0.5x T_{ON}
Promix-SM492.10-01*			
Promix-SM490.10-02*	-40 to +35	not regulated	
Promix-SM491.10-02*	-35 to +50	0.5+120	0.5x T_{ON}
Promix-SM492.10-02*			
Promix-SM490.11-01*	-40 to +30	not regulated	
Promix-SM491.11-01*	+30 to +50	0.5+120	0.5x T_{ON}
Promix-SM492.11-01*			
Promix-SM490.11-02*	-40 to +30	not regulated	
Promix-SM491.11-02*	+30 to +50	0.5+120	0.5x T_{ON}
Promix-SM492.11-02*			

*optional

6. INSTALLATION AND CONNECTION

The lock operation is controlled by means of energizing and de-energizing. For this purpose, a controller (control board) or a switch (button) is generally used. The controller is mounted in accordance with its certificate.

Connect power wires of the lock; polarity is of no significance since it does not affect operation of the lock.

Example of the lock connection to the remote control system Promix-RDS.

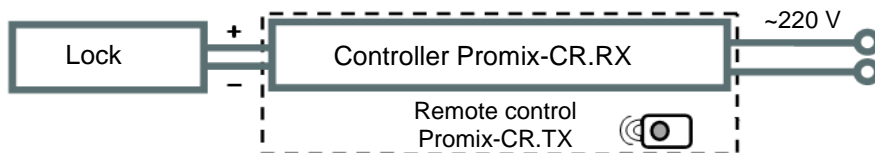

Provide a reliable electriccontact. To prevent short-circuit, insulate places of connection.

7. SPECIAL ASPECTS OF INSTALLATION AND OPERATION

- 1) The possibility of using the locks for restriction of access and the place of installation (outdoors or indoors) are determined by the **installation organization** on the basis of the design features and the mounting method, room criticality level, the purpose of the access restriction regime and other factors (the presence of security providers, video surveillance, etc.).
- 2) To prevent deformations of the door due to attempts to open the door with the lock closed, it is recommended to mount the lock in the area of the door handle.

8. MAINTENANCE

Maintenance of the lock is performed at least once every two months and includes:

- Visual inspection of the lock to check reliability of fastening. If necessary, tighten fasteners of the lock and the latch.

The lock does not need lubrication!

9. STORAGE AND TRANSPORTATION

Prior to putting into operation, the locks must be stored in the manufacturer's packing, in rooms with an ambient temperature of -30 to +50 °C and a relative humidity not higher than 98% at 25° C in compliance with storage conditions as per GOST 15150-69.

Locks transportation conditions must comply with group C as per GOST 23216-78 in terms of exposure to mechanical factors, and Ж2 as per GOST 15150-69 in terms of exposure to climatic factors.

10. SAFETY REQUIREMENTS

The design of the locks ensures safety of personnel involved in mounting and maintenance.

Due to low DC supply voltage, the products correspond to class III as per ГOCT 12.2.007.0-75 and are electrically safe.

Fire safety of the locks is ensured by use of non-combustible or hardly combustible materials, and low supply voltage.

11. DISPOSAL

The product is not hazardous for human life and health or for the environment; disposal after its service life is performed without taking any special measures for environment protection.

12. WARRANTY LIABILITIES

The manufacturer, ETC PROMIX LLC, warrants conformity of Promix-SM490, Promix-SM491, Promix-SM492 to requirements of current Technical Specifications provided that transportation, storage, installation and operation rules established in this Manual are followed.

The warranted operation period is 12 months from the date of sale but not longer than 18 months from the day of acceptance by the manufacturer's QCD.

Within the period of warranty, ETC PROMIX LLC undertakes to repair defective products free of charge. Expenses for transporting the product to the place of repair and back will be borne by the Buyer.

Warranty liabilities do not cover any defects and damages caused by:

- Improper maintenance by the Buyer;
- Use of the product under conditions that do not comply with the operation requirements;
- Mechanical damages or disassembly of the products by the Buyer;
- Non-observance of the transportation and storage rules.

Faulty products are accepted for repair only together with the latch, on the obligatory condition that factory labels are retained on the product body.

On expiration of the warranty service period, the manufacturer provides after-warranty service on a contractual basis.

To improve product quality the manufacturing plant reserves the right to make modifications to the product design without prior notice.

13. ACCEPTANCE AND PACKING CERTIFICATE

Electromechanical lock Promix-SM490 (or Promix-SM491, Promix-SM492) in quantity of ____ pieces (1 pc. by default) bearing the manufacturing date and QCD mark on the body, was manufactured and accepted in compliance with Specifications ПШБА.304268.004 ТУ, obligatory requirements of state standards and current technical documentation, recognized as fit for operation and packed by ETC PROMIX LLC.

PROMIX Engineering and Technical Center LLC
Russia, 214030, Smolensk, Krasninskoye sh., 35, lit. A
Phone: (4812) 619-330
www.promix-center.ru
vk.com/promixcenter
facebook.com/promixcenter
mail@promix-center.ru

